

1459

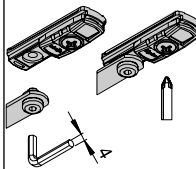

- Regolare la frizione per evitare lo sbattimento della finestra
- Adjust the clutch to avoid window slamming
- Régler la friction afin d'éviter le débaltement de la fenêtre
- Regular la fricción para evitar el batir de la ventana
- Afinar a fricção pra evitar o abatimento da janela
- Die Fraktion abstellen um das Schlagen des Fenster verhindern
- De fricție afstellen ten einde het slaan van het raam te verhinderen
- Proszę uregulować ramie hamujące aby wyeliminować uderzenia okna
- Ρυθμίστε έτσι ώστε να αποφευχθεί το χτύπημα του παραθύρου
- Регулировать прижим окна, во избежании хлопания
- Podestli tlačno silu trenja da bi se izbeglo nepotrebno udaranje prozora

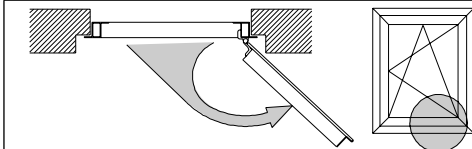
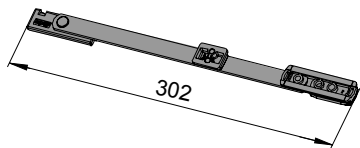
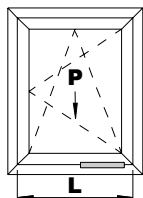

$P < 50 \text{ Kg}$   $364 \text{ mm} \leq L < 800 \text{ mm}$

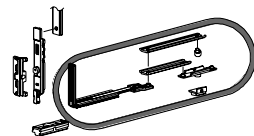
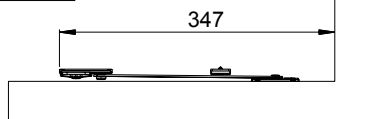
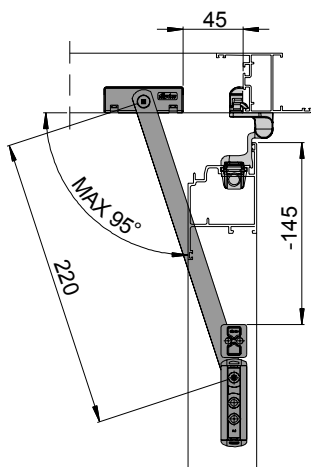
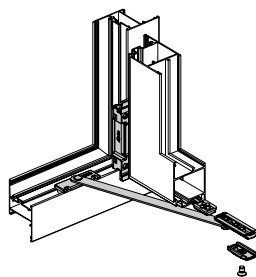

- Verificare la compatibilità del punto di chiusura
- Assess locking point compatibility
- Vérifier la compatibilité du point de fermeture
- Comprobar la compatibilidad del punto de cierre
- Comprobar a compatibilidade do ponto de fecho
- Die Kompatibilität des Schlusspunkts kontrollieren
- De compatibiliteit van het sluitpunt nazien
- Kontrolować dopasowanie punktu zamkającego
- Ελέγξει την ομοιότητα του σημείου κλειδώματος
- Проконтролировать соответственность точек закрывания
- Prekontrolisati kompatibilnost tački zatvaranja

$P \geq 50 \text{ Kg}$   $500 \text{ mm} \leq L < 800 \text{ mm}$

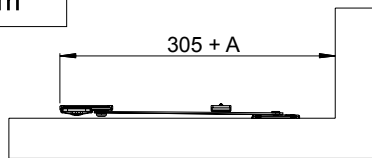
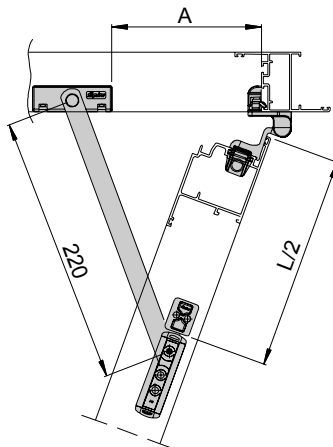
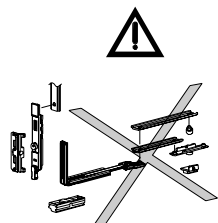

L	A
$500 \text{ mm} \leq L < 600 \text{ mm}$	100
$600 \text{ mm} \leq L < 700 \text{ mm}$	200
$700 \text{ mm} \leq L < 800 \text{ mm}$	300

**1459B**

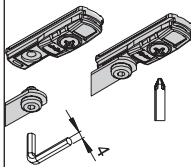
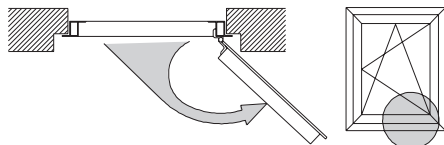
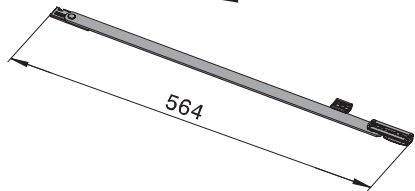

- Regolare la frizione per evitare lo sbaltonno della finestra
- Adjust the clutch to avoid window slamming
- Régler la friction afin d'éviter le débaltement de la fenêtre
- Regular la fricción para evitar el balir de la ventana
- Afinar a fricção pra evitar o abaltonno da janela
- Die Friktion abstellen um das Schlagen des Fenster verhindern
- De fricte afstellen ten einde het slaan van het raam te verhinderen
- Prosta uregłowac ramie hamujące aby wyeliminowac uderzenia okna
- Ρυθμίστε έτσι ώστε να αποφεύγεται το χτύπημα του παραθύρου
- Регулировать пружим окна, во избежании хлопанья
- Podesili tačno silu trenja da bi se izbeglo nepotrebno udaranje prozora

**P < 50 Kg 800mm ≤ L < 1700mm**

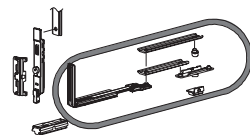
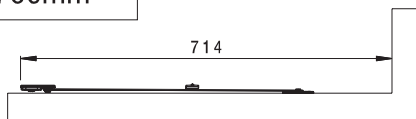
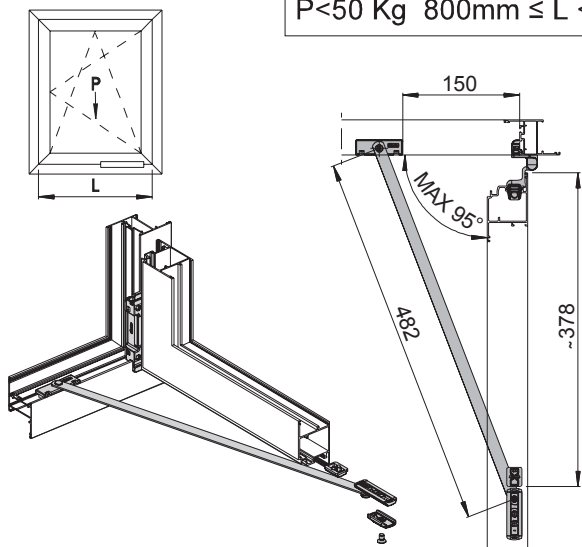

- Verificare la compatibilità del punto di chiusura
- Assess locking point compatibility
- Vérifier la compatibilité du point de fermeture
- Comprobar la compatibilidad del punto de cierre
- Comprobar a compatibilidade do ponto de fecho
- Die Kompatibilität des Schlusspunkts kontrollieren
- De compatibiliteit van het sluitpunt nazien
- Skontrolowac dopasowanie punktu zamykającego
- Ελέγξτε την συμβατότητα του σημείου κλειδώματος
- Проконтролировать соответственность точек заперания
- Prekontrolisati kompatibilnost tacni zatvaranja

**P ≥ 50 Kg 800mm ≤ L < 1700mm**

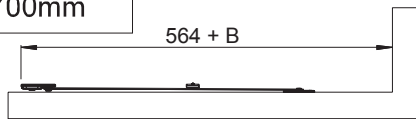
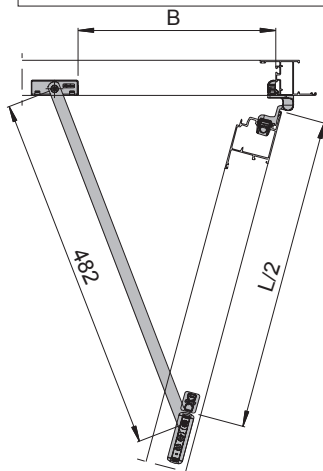

L	B
800mm ≤ L < 900mm	150
900mm ≤ L < 1000mm	250
1000mm ≤ L < 1100mm	350
1100mm ≤ L < 1200mm	450
1200mm ≤ L < 1400mm	550
1400mm ≤ L < 1700mm	600